



PVD3D1E

Proportional Valve Driver, one PWM solenoid output, epoxy potted

BENEFITS AND FEATURES:

- Versatile digital design
- Large, easy-to-use adjustments and three-digit seven-segment LED display
- Wide range of supply voltage
- Electronic limiting circuit / short circuit proof
- Load can be connected & disconnected live
- Protected against wrong connection
- Energy-efficient PWM circuit, no heat sink is required
- Current sensing maintains output regardless of changes in supply voltage and coil resistance
- Simple control with analog input, the reference voltage is locally supplied
- Environmentally sealed



SPECIFICATIONS:

- Operating voltage: 9 - 35VDC
- Maximum output current: 3A
- Ramp time: 0.0 to 99.5s
- Linearity: 0.5%
- PWM / Dither frequency: 50-500Hz
- Operating temperature: -40° to +75° Celsius
- Input signals: user selectable 0-5V, 0-10V, 0-20mA or 4-20mA
- Size: 3.00" x 0.875" x 3.25" (4.00" with flanges)
-

This product fulfills the essential requirements of
the EMC Directive 2004/108/EC: EN61000-6-1:2005, EN61000-6-3:2006



DATA SHEET

PROPORTIONAL VALVE DRIVERS



PVD3D1E

Proportional Valve Driver, one PWM solenoid output, epoxy potted

SETTINGS AND RANGE:

- H I** High, output current corresponding to the highest input, 0.00 to 3.00 A
- J9** Jog, used to simulate signal, 0.00 to 3.00 A
- L0** Low, output current corresponding to the lowest input, 0.00 to 3.00 A
- UP** Ramp up, time required for the output to increase from L0 to H I, 00.0 to 99.5 s
- dn** Ramp down, time required for the output to decrease from H I to L0, 00.0 to 99.5 s
- db** Deadband, output is disabled when command signal is less than this setting, in %
- dF** Dither frequency, 050 to 500 Hz
- in** Input signal selection, 005 (0-5V), 010 (0-10V), 020 (0-20mA) or 420 (4-20mA)
- di** Display orientation, normal or up-side-down
- SA** Save settings

PVD3D1E

SET-UP PROCEDURE:

At power up, you may rotate the left side control **#** to read **ot** - the actual solenoid output current directly in Amps or **in** - the command input signal in V or mA, corresponding to the input range preselected. To enter set-up mode, rotate right side control *****; the display will show the settings sequentially: **H I**, **J9**, **L0**, **UP**, **dn**, **db**, **dF**, **in**, **di** and **SA**.

When you reach the setting that you want to modify, rotate **#** up or down to the desired value. To modify another setting, rotate ***** and repeat. The Driver is fully functional during the set-up procedure with any adjustments effective immediately (except the input range selection that becomes effective only after saving). In order to write the new settings in the memory and return to normal mode of operation, rotate ***** until the display shows **SA** and then rotate **#** one full turn. If you do not want to keep the new settings, simply power down without saving.

WE RESERVE THE RIGHT TO DISCONTINUE MODELS OR CHANGE SPECIFICATIONS WITHOUT NOTICE OR INCURRING OBLIGATION



PVD3D1E

Proportional Valve Driver, one PWM solenoid output, epoxy potted

WIRING DIAGRAMS:

With signal from Analogue Card/PLC:

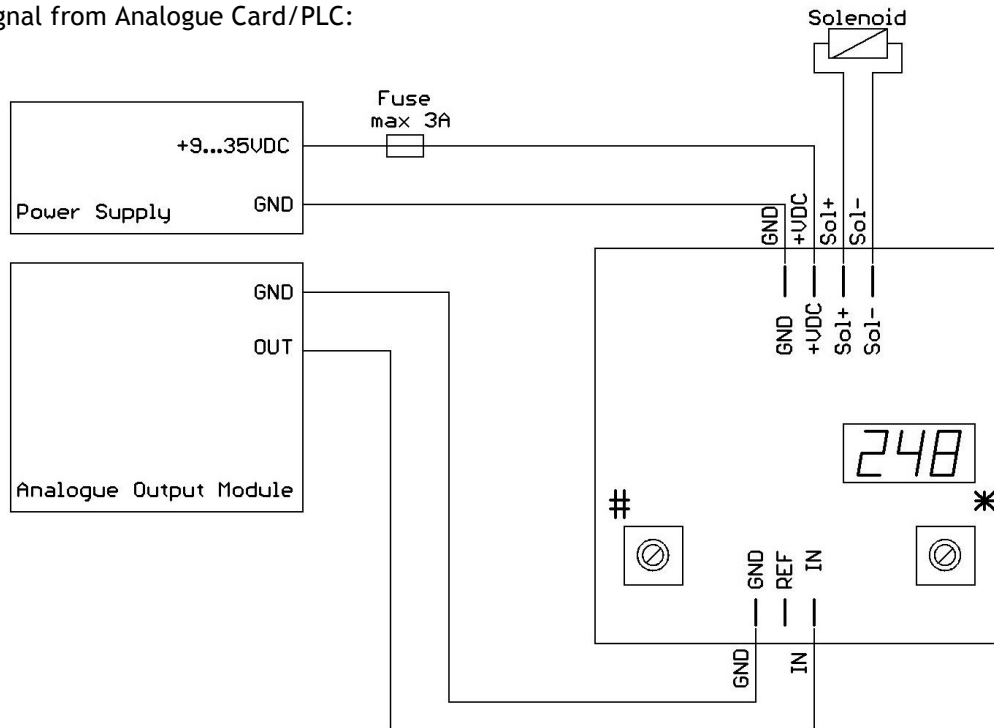

With signal from potentiometer/joystick:

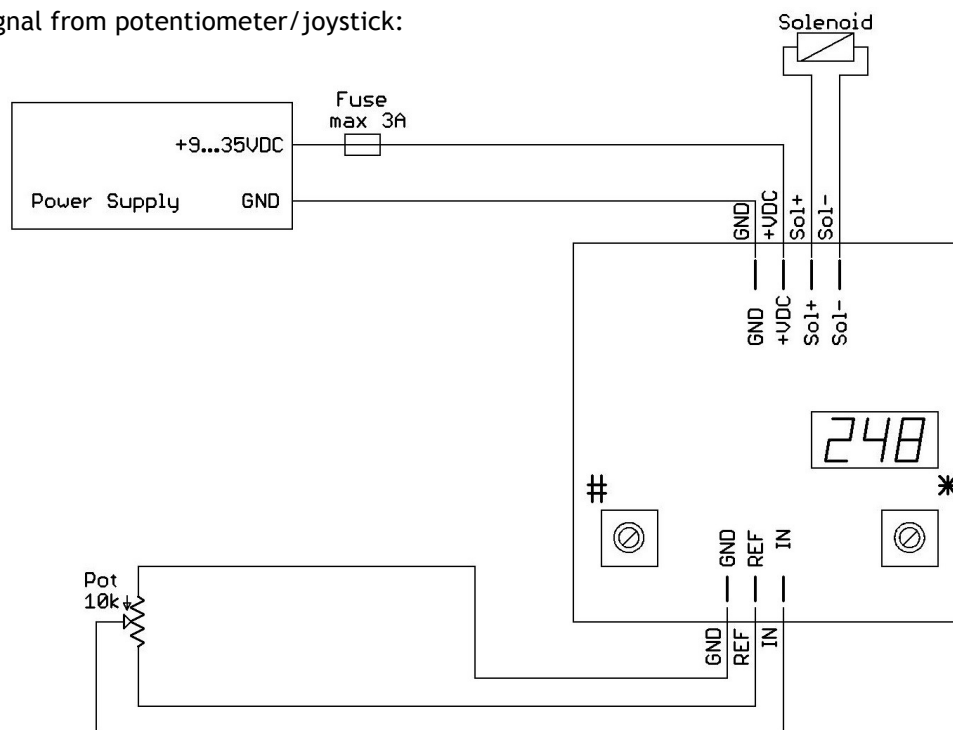

PVD3D1E